

M. C. JOHNSON.  
LATHE HEAD.

No. 458,423.

Patented Aug. 25, 1891.

Fig. 1

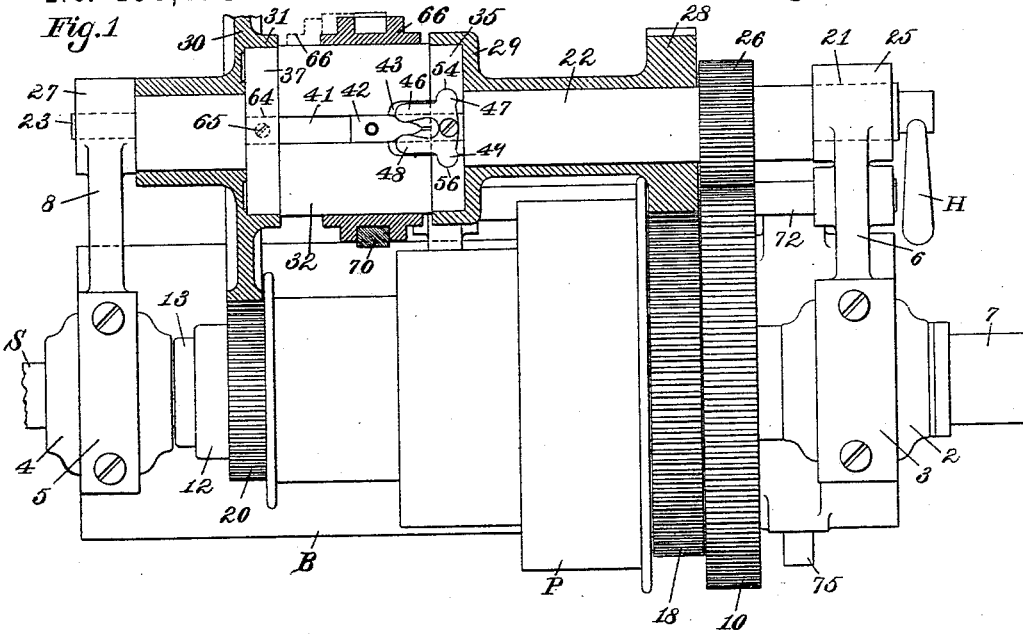
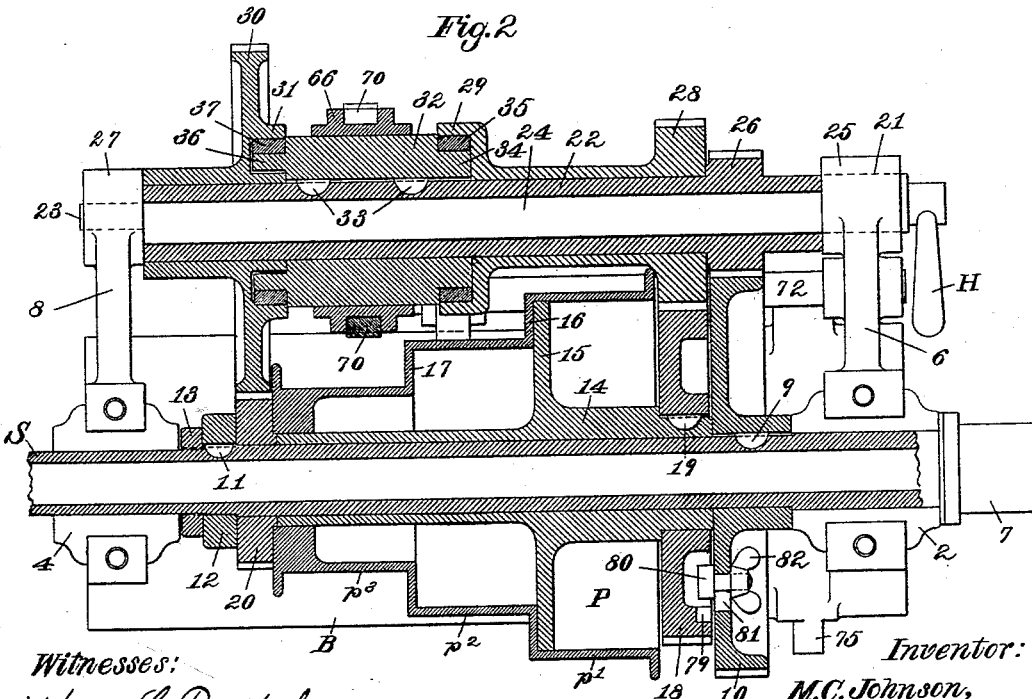

Fig. 2



Witnesses:

*Henry L. Reckard.*  
*H. Mallner*

Inventor:

*M.C. Johnson,*  
*By his Attorney,*  
*J. F. Richards*

M. C. JOHNSON.  
LATHE HEAD.

No. 458,423.

Patented Aug. 25, 1891.

Fig. 3

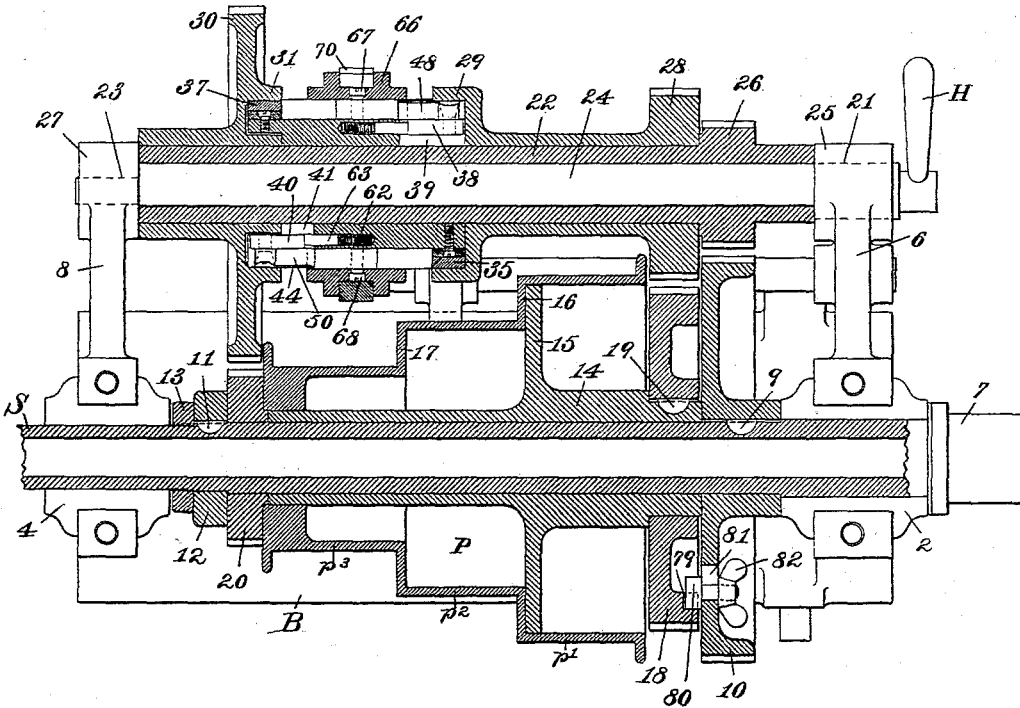
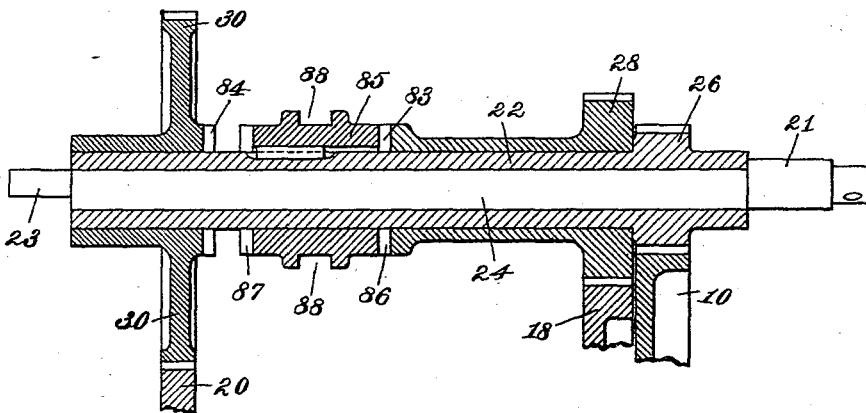

Fig. 14



Witnesses:  
*Henry L. Reckard.*  
*H. Mattner*

Inventor:  
*M. C. Johnson,*  
 By his Attorney,  
*F. H. Richards.*

# M. C. JOHNSON. LATHE HEAD.

No. 458,423.

Patented Aug. 25, 1891.

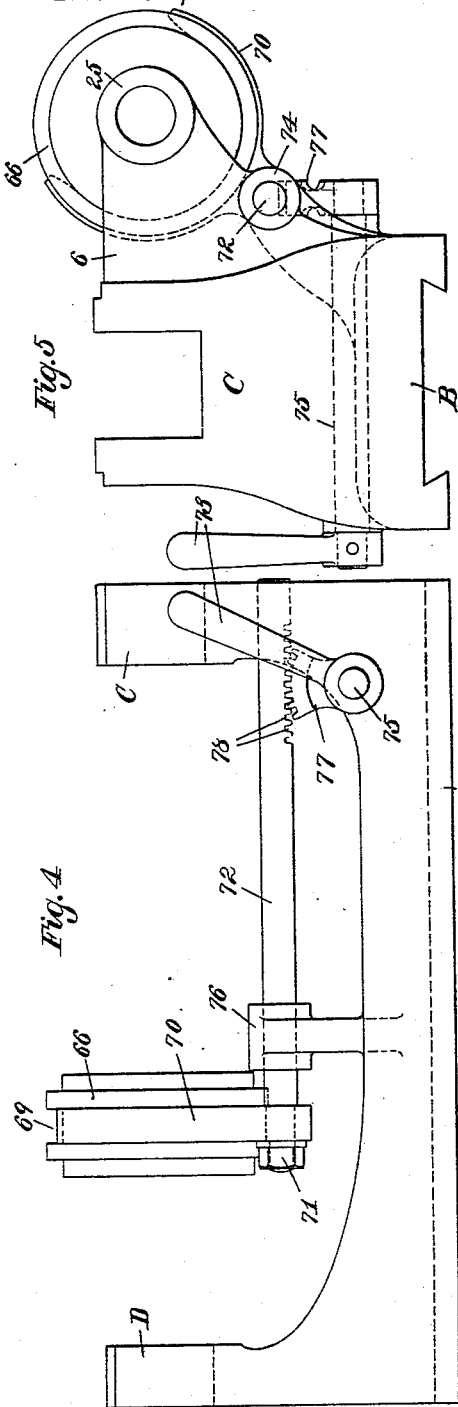

Fig. 5

Fig. 4

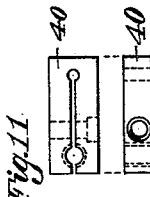

Fig. 11

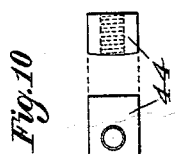

Fig. 10

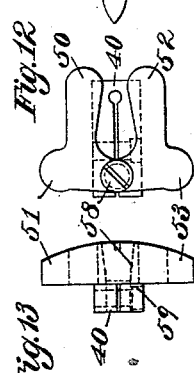

Fig. 12

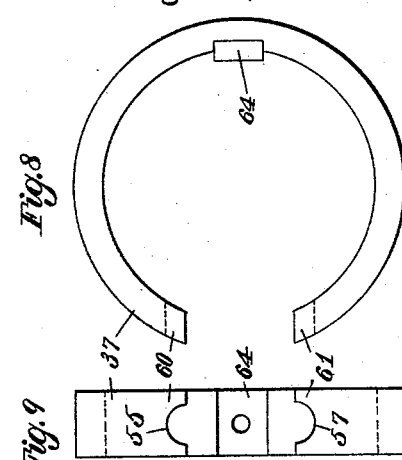

Fig. 8

Fig. 9

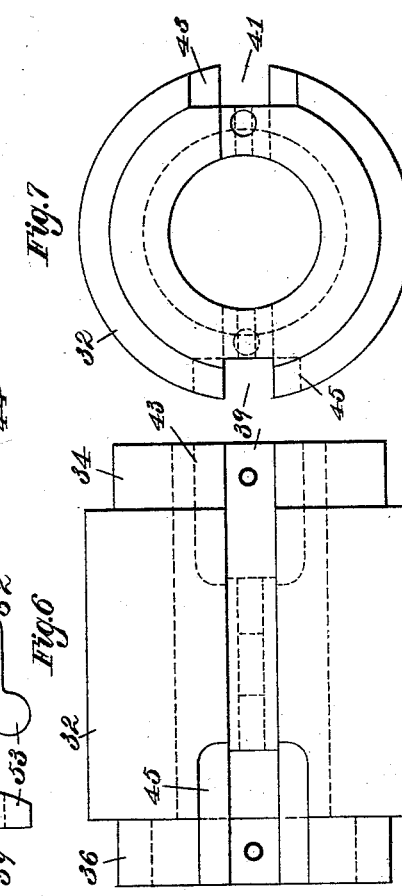

Fig. 7

Fig. 6

Witnesses:

*Henry L. Reckard.*  
*H. Mattner*

Inventor:

*M. C. Johnson,*  
*By his Attorney, J. W. Richards.*

# UNITED STATES PATENT OFFICE.

MOSES C. JOHNSON, OF HARTFORD, CONNECTICUT.

## LATHE-HEAD.

SPECIFICATION forming part of Letters Patent No. 458,423, dated August 25, 1891.

Application filed January 7, 1891. Serial No. 377,005. (No model.)

*To all whom it may concern:*

Be it known that I, MOSES C. JOHNSON, a citizen of the United States, residing at Hartford, in the county of Hartford and State of Connecticut, have invented certain new and useful Improvements in Lathe-Heads, of which the following is a specification.

This invention relates to clutch-heads for lathes and screw machines, the object being to furnish a back-gear lathe or lathe-head comprising clutch mechanism for changing the speed of the spindle while the machine is running, and also to provide an increased number of speeds relative to the number of grades on the driving cone-pulley.

In the drawings accompanying and forming a part of this specification, Figure 1 is a plan view, partially in section, of a lathe-head embodying my present improvements. Fig. 2 is a horizontal section or sectional plan view of the lathe-head. Fig. 3 is a view similar to Fig. 2, showing the back shaft thrown back to disengage the back gearing from the spindle-gears and showing also some other details in different positions. Fig. 4 is a front elevation of the lathe-head frame, together with certain details carried thereby. Fig. 5 is an end elevation of the parts shown in Fig. 4. Fig. 6 is an enlarged plan view of the clutch-ring carrier. Fig. 7 is an end elevation of the same. Fig. 8 is an end view of one of the clutch-rings. Fig. 9 is a side view of said ring. Fig. 10 shows the wedge in plan view and end elevation, respectively. Fig. 11 shows a plan view and side elevation of the clutch-lever carrier. Fig. 12 is a plan view of the clutch-levers assembled on the clutch-lever carrier. Fig. 13 is an end view of the parts shown in Fig. 12. Fig. 14 is a sectional view similar to a portion of Fig. 2, showing a different form of clutch for engaging and disengaging the loosely-mounted back gears on the back shaft.

Similar characters designate like parts in all the figures.

The lathe-head frame may be of any ordinary description—as, for instance, the well-known form thereof shown in the drawings, consisting of the base B, having the uprights C and D for carrying the spindle-boxes 2 and 4, (held in place by caps 3 and 5 and screws,

substantially as shown,) suitable arms, as 6 and 8, for carrying the back shaft, and means for carrying the clutch-sleeve-actuating devices. The lathe spindle S is or may be of the ordinary description, being fitted to turn in said boxes 2 and 4 and adapted to carry the usual chuck or face-plate on the end thereof. On said spindle, contiguous to one end of the front bearing 2, there is the usual latch-gear 10, which may be fixed on the spindle by means of a "Woodruff key" 9, as shown in Figs. 2 and 3. Beyond this gear the cone-pulley P is fitted to freely rotate on the spindle between said gear 10 and the collar 12, which collar is keyed to the spindle by a suitable key, as 11, and is held in place longitudinally by the nut 13, as will be understood from Figs. 2 and 3. The driving cone-pulley P may be of any suitable construction—as, for instance, the composite construction shown in Figs. 2 and 3 and consisting of the collar 14, having the flange or plate 15, and the cone proper consisting of the several grades  $p'$   $p^2$   $p^3$ , connected by the disks or plates 16 and 17. At its larger end said cone fits the aforesaid flange 15 and at its smaller end fits the left-hand end of the collar 14, being permanently fastened to said flange and collar in a well-known manner by a system of pins. (Not shown.) The cone-pulley P carries two driving-gears 18 and 20, fixed to the right and left hand ends thereof, respectively, substantially as shown. The larger gear 18 is shown carried on the right-hand end of the collar 14 of the cone P, being fixed thereto by the key 19, while the other gear or pinion 20 is fixed to the left-hand end of said cone by suitable screws and pins. (Not shown.) This preferred and usual construction of the driving-cone may of course be modified in various ways within the scope and limits of my invention. The back shaft or back-gear shaft is supported substantially parallel to the lathe spindle-head and is carried by means constructed for shifting said shaft toward and from the lathe-spindle, whereby to engage and disengage the back gears from the spindle-gears. This movement may be accomplished by supporting the back shaft by journals at the ends thereof in sliding boxes movable toward and from the

spindle after an old and well-known manner. I prefer, however, to employ the well-known tubular back shaft 22, carried on an eccentric shaft 24, which is supported by eccentric journals 21 and 23 in the bearings 25 and 27, formed on the aforesaid lathe-head arms 6 and 8, respectively. As shown in Fig. 2, said eccentric shaft 24 stands forward of the axis of its said journals, while in Fig. 3 said shaft stands back of said axis, as will be understood from the dotted lines in said figures. For turning said shaft to shift the tubular back shaft from its forward to its rearward position, and vice versa, the eccentric shaft is provided at one end thereof with the handle H, a suitable stop (not shown) being usually provided for limiting the rotary movement of said eccentric shaft. The back shaft 22 has fixed or formed thereon the driving-pinion 26, adapted to mesh with and drive the aforesaid spindle-gear 10. The back shaft carries, mounted to freely rotate thereon, two gears 28 and 30, meshing with the aforesaid large and small cone-pulley gears 18 and 20, respectively. The larger back-shaft gear 30 is provided with the friction-rim 31, while the smaller back-shaft gear 28 is provided with the similar friction-rim 29. Between said friction-rims the back shaft carries the friction-ring carrier 32, which carrier is rigidly fixed on said shaft by suitable means—as, for instance, the keys 33. Said carrier 32 is extended, of reduced diameter at each end thereof, within said friction-rims. The right-hand end 34 of the carrier is furnished with the friction-ring 35, while the left-hand end 36 of said carrier carries the corresponding friction-ring 37, as indicated in Figs. 2 and 3. The construction of the clutch details is best shown in Figs. 6 to 13, inclusive, reference being had also to the views of the assembled clutch mechanism in Figs. 1, 2, and 3. The friction-ring carrier 32 has on the opposite sides thereof the similar slots 39 and 41, in which the clutch-lever carriers 38 and 40, and also the wedges 42 and 44, are fitted to slide. At one end of said grooves each of the same is widened to form chambers 43 and 45 for receiving the clutch-levers, as will be understood from Figs. 1, 6, and 7. The wedge 42 in the groove 41 operates the levers 46 and 48 for operating the clutch-ring 35, while the wedge 44 in the opposite groove stands in a reverse direction for operating the opposite set of clutch-levers 50 and 52 to actuate the opposite clutch-ring 37. The fulcrum-bearings 47 and 49 and 51 and 53 of the clutch-levers fit in corresponding sockets 54 and 56 and 55 and 57, respectively, freely in the clutch-ring, as will be understood by comparison of Figs. 1, 8, 9, 12, and 13. On their inner sides opposite their fulcrum-bearings, as shown in Figs. 12 and 13, said levers are fitted to the clutch-lever pivot-screw 58, which screw is secured in the carrier 40 by a clamp-screw 59, as indicated by dotted lines in Fig. 13. When thus assembled, said le-

vers act on the principle of a toggle-joint to expand the friction-ring within its friction-rim by forcing apart the ends 60 and 61 of said ring, Figs. 1, 8, and 9. During this operation the wedge of course enters between the arms 50 and 52 of the clutch-levers, while the carrier 40 and its pivot-screw 58 slide in the groove of the clutch-ring carrier. For reversely actuating the clutch-levers to release the clutch a spring, as 62, is provided, which acts through a plunger, as 63, bearing against the inner end of said carrier, as shown in Fig. 3 and indicated in Fig. 7. The clutch-ring opposite to its aforesaid sockets 55 and 57 is furnished with a key, as 64, which fits in one end of the carrier-groove, being held in place by a suitable screw, as 65. By this means on expanding the clutch-ring within the friction-rim the driving-power is communicated to the carrier 32 through said key 64 instead of through the sliding lever-carrier 40, thereby avoiding any tendency of said carrier to stick in its groove. The wedges 42 and 44 are connected by screws 67 and 68, respectively, to the inner side of the clutch-sleeve 66, which sleeve has a groove 69 formed on the outer side thereof for receiving the fork 70, which is fixed to the left-hand end of the shipper-rod 72. This rod, being fixed in the lower end of said fork by the nut 71, is supported to slide in bearings 74 and 76, formed on the frame B, and actuated by the handle 73 through the shaft 75 and the segment 77, fixed on said shaft and meshing with the teeth 78 on the shipper-rod. Said shipper-shaft 75 is shown carried in bearings formed in the forward end of the lathe-head frame, the said segment and handle fixed thereon being of relatively short radii; but obviously said shaft may be located lower in or below said frame.

When organized as herein described, my improved clutch-head is adapted for three modes of operation, the first being shown in Fig. 3, wherein the back shaft is thrown back to disengage all of its gears from the cone-pulley and spindle-gears, the cone-pulley being locked to the spindle by the sliding dog or lock-bolt 80, which engages in the mortise 79, Fig. 2, of the cone-pulley gear 18, said bolt being fitted to slide in the slot 81 of the spindle-gear 10 and provided with the thumb-nut 82 for setting said bolt in its inner position (shown in Fig. 2) or its outer and working position. (Shown in Fig. 3.)

The second mode of operation is shown in Fig. 1, wherein the back shaft is thrown forward to engage all of the gears thereon with the cone-pulley and spindle-gears, the smaller clutch-gear 28 being frictionally fixed to the back shaft by its aforesaid clutch, as indicated by the position of the clutch-sleeve 66, which is shown shifted to its right-hand position, thereby forcing the wedge 42 between the levers of the clutch-ring 35, thus engaging said ring with the rim 29 of said gear 28.

In this arrangement the larger cone-pulley gear 18 drives the back shaft through the said smaller clutch-gear 28, and the shaft thus rotated drives the spindle through the pinion 5 26 and the spindle-gear 10. This portion of the gearing may of course be used, as set forth, with the driving-belt on three of the grades  $p'$ ,  $p^2$ , and  $p^3$  of the cone-pulley, thus obtain- 10 ing three speeds in addition to the three obtained without the use of the back gearing.

The third arrangement is that in which the back gears stand in engagement, as in Figs. 1 and 2, while the friction-sleeve 66 is shifted toward the left hand, as indicated by dotted 15 lines in Fig. 1, thereby, in a similar manner to that just described, frictionally fixing the larger back gear 30 to the back shaft. In this arrangement the smaller cone-pulley gear 20 meshes with said largest back-shaft gear 30, 20 rotates said back shaft at a correspondingly-reduced speed, and drives the spindle through the aforesaid pinion 26 of the back shaft and spindle-gear 10, thus obtaining three additional still slower speeds for the lathe-spindle 25 and making nine speeds in all with a three-grade cone-pulley. The difference in spindle speeds obtained by shifting the clutch to engage one or the other friction-rim corresponds, of course, to the proportion between 30 the sets of gears comprising in the one case the pairs 18 28 and 26 10 and in the other case the pairs 20 30 and 26 10.

It will of course be understood that the particular kind and construction of clutch 35 herein shown and described is not essential to my present improvements; but I have shown and described herein the clutch which I deem the most suitable and effective for the required purpose, it being the improved 40 clutch described and claimed in Letters Patent No. 298,979, granted to me May 20, 1884.

By placing the clutch on the back shaft in accordance with my present improvement 45 the amount of power transmitted through the shaft is reduced in proportion to the gearing, whereas by the old method of placing the clutch on the spindle the clutch-faces necessarily held the whole power of the machine. The clutch, being located on the back shaft 50 contiguous to the first or large gear of said shaft, occupies the space adjacent to the small grades of the cone-pulley, thus facilitating compactness of construction, while leaving ample room for the mechanism. Another ad- 55 vantage of this construction is that the clutch mechanism is always accessible for disassembling the lathe-head.

Instead of the preferred form of friction-clutch herein described in connection with 60 Figs. 1 to 13, inclusive, I may substitute the well-known form of toothed clutch shown in sectional view in Fig. 14. In this form of the clutch-head the back shaft is supposed to be laterally movable, as above described; but 65 the loosely-mounted back gears 28 and 30, instead of being provided with friction-rims, are

furnished with the clutch-teeth 83 and 84, respectively, while the back shaft is provided with the sliding clutch 85, splined thereto and having the clutch-teeth 86 and 87 for engaging 70 with the teeth of said gears, respectively. The sliding clutch has or may have a groove 88, corresponding to the groove 69 in the sliding sleeve 66, whereby the toothed clutch may be operated by means of a fork carried on 75 the sliding clutch-rod 72 and corresponding to the above-described fork 70. It will be obvious that the usual operation of my improved lathe-head is the same, whichever type of back-shaft clutch may be employed. 80

Having thus described my invention, I claim—

1. In a lathe-head, the combination, with the lathe-spindle and a gear fixed thereon, of the driving-pulley carrying a driving-gear, 85 the back shaft supported to be shifted toward and from the lathe-spindle and driving-pulley and carrying a gear adapted to mesh with the spindle-gear, a gear loosely mounted on the back shaft and adapted to 90 mesh with the pulley-gear, a clutch for engaging and disengaging the loosely-mounted gear with and from the back shaft, and means for shifting the back shaft toward and from the lathe-spindle. 95

2. In a lathe-head, the combination, with the lathe-spindle and a gear fixed thereon, of the driving-pulley carrying two driving-gears of different diameters, the back shaft carrying a gear meshing with the spindle- 100 gear, two gears loosely mounted on the back shaft and meshing with the large and small pulley-gears, respectively, and a clutch for engaging and disengaging the loosely-mount- 105 ed gears with and from the back shaft.

3. In a lathe-head, the combination, with the lathe-spindle and a gear fixed thereon, of the driving-pulley carrying two driving-gears of different diameters, the back shaft supported to be shifted toward and from the 110 lathe-spindle and driving-pulley and carrying a gear adapted to mesh with the spindle-gear, two gears loosely mounted on the back shaft and adapted to mesh with the large and small pulley-gears, respectively, a clutch 115 for engaging and disengaging the loosely-mounted gears with and from the back shaft, and means for shifting the back shaft toward and from the lathe-spindle.

4. In a lathe-head, the combination, with 120 the lathe-spindle and a gear fixed thereon, of the driving-pulley carrying two driving-gears of different diameters, the back shaft carrying a gear meshing with the spindle-gear, two gears loosely mounted on the back 125 shaft and meshing with the large and small pulley-gears, respectively, each of said loosely-mounted gears having a friction-rim, substantially as described, a friction-clutch, substantially as described, carried on the back 130 shaft and constructed for engaging each of said friction-rims alternately, and means, sub-

stantially as described, for operating said clutch.

5 In a lathe-head, the combination, with the laterally-movable back shaft carrying back gears loosely mounted thereon and provided with a clutch for engaging and disengaging said gears with and from the shaft

and having a sliding clutch-sleeve, of the sliding clutch-rod and the fork carried on said rod and engaging said sliding sleeve.

MOSES C. JOHNSON.

Witnesses:

H. MALLNER,

HENRY L. RECKARD.